



FIBROUS GLASS DUCT BOARD WHITE PAPER



Prepared By:
Steve Bolibruck, Brad Oberg
IBACOS, Inc.

April 15, 2003



This document has been compiled from previously published documents and from IBACOS' field observations. Its intention is to inform and is not intended to provide specific recommendations or to serve as an engineering document.



© IBACOS, Inc. 2003

IBACOS

Table of Contents

- 1. Document Scope and Introduction 1**
 - 1.1 Introduction 1
- 2. Key Criteria for Selecting a Duct Construction Method 2**
 - 2.1. Thermal Performance 2
 - 2.2. Pressure Loss and Sizing 2
 - 2.3. Condensation Resistance 3
 - 2.4. Physical Strength 4
 - 2.5. Installation and Fittings 4
 - 2.6. Cleaning 5
 - 2.7. Mold Growth Potential 5
 - 2.7.1. Laboratory tests confirmed that fibrous glass ducts do not support mold growth. ... 5*
 - 2.7.2. Research confirms that mold growth is not surface specific..... 6*
 - 2.7.3. HVAC systems may create conditions that are suitable for mold growth on any duct material. 6*
 - 2.7.4. Standard uncoated fibrous glass duct board has a higher surface area than metal duct. 6*
 - 2.8. Leakage 7
 - 2.9. Acoustic Performance 7
 - 2.10. System Application..... 7
 - 2.11. Fire and Flame Resistance/Rating 11
 - 2.12. Code Compliance..... 11
 - 2.13. Fiber Erosion 11
- 3. Issues Specific to Fibrous Glass Duct Construction 13**
 - 3.1. Air-handling units must be properly installed and maintained. 13
 - 3.2. Duct surfaces can become wet in the return plenum of up-flow systems. 15
- 4. Recommendations 18**
- 5. References 19**

Fibrous Glass Duct Board White Paper

1. Document Scope and Introduction

This white paper is intended for a generic industry and builder audience to increase knowledge of using fibrous glass duct board in common residential HVAC applications.

1.1 Introduction

In this white paper, IBACOS describes the characteristics and benefits of fibrous glass duct board, and addresses issues specific to fibrous glass duct construction, including the concern that fibrous glass ducts collect water and support growth of mold. IBACOS assumes no responsibility and accepts no liability for the application of the principles or techniques contained in this white paper.

Fibrous glass duct board is 1-, 1½-, or 2-inch thick rigid boards of insulation material manufactured from resin bonded inorganic glass fibers. This bonding keeps the fibers in place through the life of the installation. The exterior surface of the board is a factory-applied reinforced aluminum foil air barrier and water vapor retarder. The edges of the board are formed by machine to create a shiplapped edge or grooves, to allow the boards to be joined to build straight ducts of any size or length. Duct system components such as tees, offsets, elbows, and transitions may be fabricated from flat duct board. Fibrous glass duct boards are fabricated into ducts to make a fibrous glass duct system. Equipment such as electric or hot water in-line heaters, manual or motorized dampers, registers and grilles, diffuser drops, and access doors may be incorporated into a fibrous glass duct system.

Four companies in the U.S. produce duct board. All manufacturers produce a basic fibrous glass duct board with the core material exposed to the airstream with no additional coating. A higher performance duct board is produced by laminating a facing, adding a coating, or a combination of both to the inside surface. Added performance benefits include additional abuse resistance, reduced friction, and easier cleaning. The enhanced surfaces also are more resistant to the absorption of accidental water exposure. Since this paper was originally drafted in February 2003, all manufacturers have introduced “standard” duct board products that have facings instead of uncoated or untreated airstream surfaces.

With these products, the industry has created attractive alternatives to uncoated duct board. These new generation products reduce the fiber surface area, the moisture absorbing potential, and the surface friction. IBACOS advocates using the newer generation of fiber duct board with matte coating or laminated facing.

Fibrous glass duct board is rigid, which allows the ducts to hold their shape and be suspended much like metal duct. Ducts made of duct board are easily configured into a system of main trunks and run-outs. In residential systems, operating pressures are low enough that additional reinforcement is not needed. The main advantage of fibrous glass duct systems is that the duct has thermal insulation and does not require external insulation. When following the Sheet Metal and Air Conditioning Contractors’ National Association’s (SMACNA) (1992) recommendations for installation, ducts will be relatively airtight, durable under most applications, resistant to microbial growth, and quite effective at attenuation of duct-borne noise at high frequencies. For these reasons, IBACOS recommends the use of fibrous glass duct board in certain locations.

2. Key Criteria for Selecting a Duct Construction Method

2.1. Thermal Performance

According to the North American Insulation Manufacturer's Association (NAIMA) (2002), the thermal performance of fibrous glass duct systems is determined by the thickness of the fibrous glass duct board. The 1-inch fibrous glass duct board has an R-value at 75°F of $4.3 \text{ h}\cdot\text{ft}^2\cdot\text{°F}/\text{Btu}$. The 1½-inch board has an R-value of 6.5. The 2-inch board has an R-value of 8.7. R-Value varies slightly by manufacturer.

2.2. Pressure Loss and Sizing

When sizing fibrous glass duct board systems, there are two key considerations. First, make sure that the fabrication drawings clearly state interior dimensions, as many new fabricators will measure to the outside and have restricted flow. Second, design the ducts for the appropriate friction rate associated with the material specified, which is based on the interior finish.

Standard uncoated fibrous glass duct board is classified as a medium-rough surface by ASHRAE, while laminated and coated fibrous glass duct boards have surfaces that are less rough. When sizing fibrous glass duct board, the manufacturer's literature and design criteria should always be consulted. However, the pressure drop due to friction can be calculated and examined as outlined in the 2002 *ASHRAE Fundamentals Handbook*.

Given a standard 8" x 10" section of duct at a length of 100 feet, the equations in ASHRAE can be used to evaluate the pressure drop associated with the additional friction of standard uncoated fibrous glass duct board. Going through a series of friction loss calculations for air velocities ranging from 500 feet per minute (fpm) to 1,000 fpm, the calculated pressure drop for fibrous glass duct board is higher than that of sheet metal ductwork of the same criteria, and grows as the airflows increase. At the lowest calculated airflows, fibrous glass duct board has an average of 30% more pressure drop. As the airflows increase in the same size section of duct, fibrous glass duct board continues to have a greater pressure drop, growing to an average of 34% more than that of sheet metal. This trend continues as the velocities approach 1,000 fpm, growing to an average of 38% more pressure drop when compared to sheet metal ductwork. A comparison of total pressure drop is presented in Figure 1. These values are not unusual and do demonstrate the importance in sizing fibrous glass duct board appropriately. Again, the manufacturer's literature should be consulted to ensure the appropriate friction rates are used to size ductwork.

Fibrous Glass Duct Board White Paper

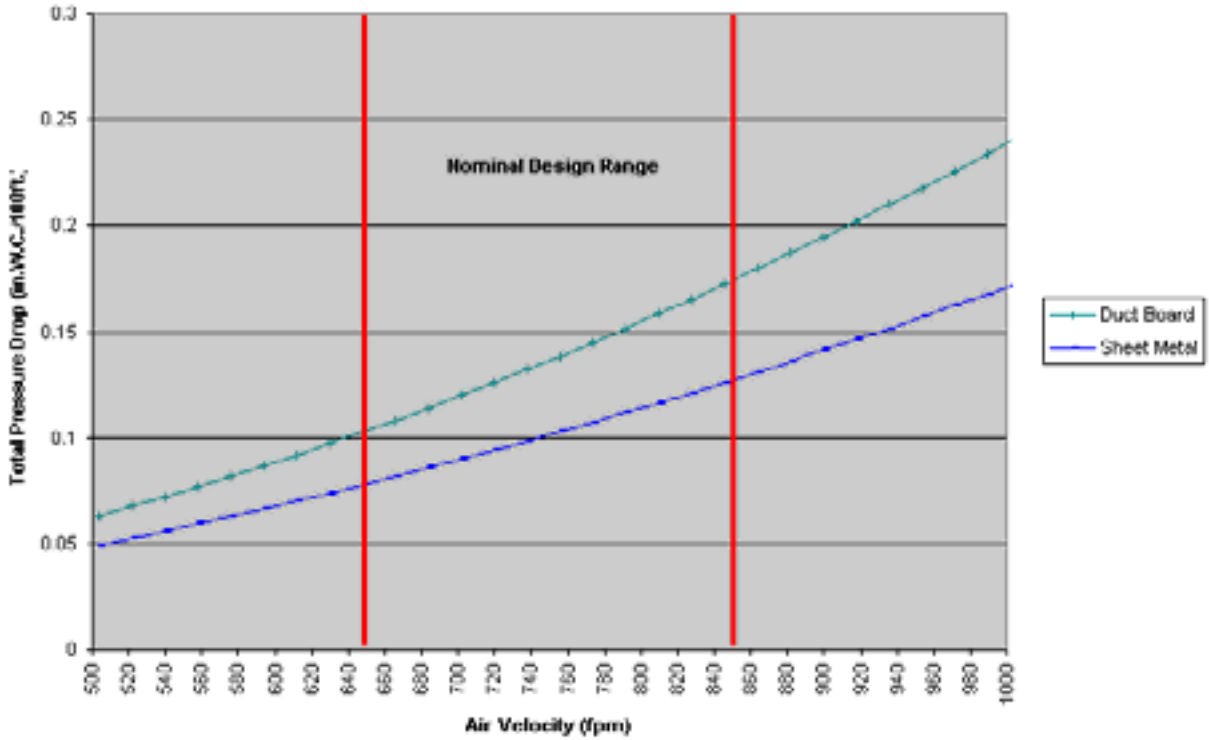

Figure 1. Friction Comparison

2.3. Condensation Resistance

According to NAIMA (1996), the fibrous glass duct’s outer jacket acts as a vapor retarder to help control moisture condensation in the air-handling system, thus reducing the opportunity for water damage, or for microbial growth and amplification.

In insulated duct systems, condensation on the surface of the ductwork is only a concern during the cooling season. There are two conditions where condensation would typically be a concern. As well, there are two areas during the heating season where it is typically thought that there is potential for condensation to occur. The inherent attributes of ductwork constructed of fibrous glass duct board provide solutions to these conditions:

1. During heating mode, the air inside the ductwork is hot and dry with little potential for condensation on the backside of the exterior surface.
2. When ductwork is located in an unconditioned space during heating mode, all the energy is focused on drying, and there is little potential for condensation.
3. During cooling mode, condensation potential from the interior is limited because the saturated air exiting the cooling coil increases in temperature, which increases the dew-point, again limiting the potential for condensation.
4. When ductwork is located in an unconditioned space during cooling mode, an adequate thickness of insulation will prevent the cold interior air from lowering the exterior surface of the fibrous glass

Fibrous Glass Duct Board White Paper

duct board to a temperature suitable for condensation. This is the one mode where condensation can occur on the exterior of the ducts, and similar performance can be seen in fibrous glass duct board as well as insulated sheet metal ducts. Humid attic air will condense on cold surfaces. Increasing the insulation levels will raise the exterior surface temperature, reducing condensation. Southern homes in hot and humid environments may need to use an R-8.5 insulation level, not to conserve cooling energy, but to control condensation.

2.4. Physical Strength

The following test results have been documented in the *Fibrous Glass HVAC Duct Systems: Proven Performance* report by NAIMA (1996). The tests were performed by NAIMA using Underwriters' Laboratories (UL) test procedures for structural integrity where duct samples were subjected to a variety of tests. Based on test data, fibrous glass duct board is a strong and durable material system.

In one test procedure where a duct sample is subjected to the impact of a two-pound rod dropped in several locations, including joints, fibrous glass duct was found to be puncture-resistant.

In another test, a duct span was subjected to static load. The test result was that the structural integrity of fibrous glass duct exceeds that required in actual installations.

In a third test where sealed duct sections are subjected to 2½ times rated positive and negative pressures, fibrous glass ducts successfully withstood positive and negative test pressure 2½ times higher than rated operating pressures. This surpasses the 50% margin required in most installations.

2.5. Installation and Fittings

Fibrous duct construction should conform to the SMACNA *Fibrous Glass Duct Construction Standards* or NAIMA *Fibrous Glass Duct Construction Standards*.

Installation of the supply trunk and main return duct are done using straight duct modules fabricated from flat sections of fibrous glass duct board. Joints and longitudinal seams need to be sealed using a UL 181 approved closure system as outline in NAIMA'S *Fibrous Glass Duct Construction Standards*, 2nd edition (1997). Fibrous glass ducts are light and can be supported with a typical number of hangers, again following SMACNA or NAIMA standards.

Attachment of insulated flex duct to fibrous glass ducts is as simple as spinning in a collar, sealing the pressure liner, and securing the vapor retarding covering to the facing of the fibrous glass duct board.

When building elbows or installing volume or zoning dampers, adequate support must be provided. Exterior bracing sections may be added, or short sections of metal frame may be inserted inside the duct. All but heavy accessories may be supported within the fibrous glass duct board sections. These accessories can still be used with fibrous glass duct board but will simply need to be independently supported, as is the case with all duct material. Turning vanes and duct offsets are achieved without added bracing.

Fibrous Glass Duct Board White Paper

2.6. Cleaning

As NAIMA reports (1998), fibrous glass duct board may be cleaned with conventional methods. The three most popular methods are air sweeping, vacuuming, and rotary brush. Never use steam or any cleaning method that involves water to clean fibrous glass duct board. With air sweeping, a nozzle is inserted into the duct, and the accumulated dust is lifted by a compressed air stream and carried away by a general flow of air induced by a vacuum down stream. Contact cleaning is achieved by a vacuum cleaner with a low stiffness brush used to vacuum the inside surface of the duct. With a low stiffness rotary brush, a powered head is inserted into the duct with long bristles that lift the dirt by direct impact on the surface.

The concern about duct cleaning is the issue of fiber erosion. However, the only aggressive method is the rotary brush, where poor attention may allow the brush to stay in one location too long, damaging the surface. The newest generation of internally faced products addresses this concern, but also, ensuring that the brush is kept moving, and using a softer whisker brush would eliminate these issues, according to NAIMA (1998).

Access to the duct for cleaning is achieved by using a knife to cut access panels into the fibrous glass duct board. There are several different ways to cut these accesses, and each cut piece can easily be replaced and sealed back into the duct after the cleaning is complete. Guidelines are available from the NAIMA *Cleaning Fibrous Glass Insulated Air Duct Systems Recommended Practice* brochure (1998).

If adequate care is given to keeping ductwork clean during the construction process, fibrous glass duct board should not need initial cleaning. For off-site fabrication, it is important that the fibrous glass duct board is swept out after fabrication to remove any loose fibers that may be left inside the duct from cutting the fibrous glass duct board. Care should be taken during transportation of the duct fabricated off site to keep it clean and free of contaminants. It is essential that the ducts be protected and kept dry during transit so as to prevent moisture entering the duct system prior to its installation. If the fibrous glass duct board is fabricated on the job site, it will also need to be properly cleaned out prior to it being installed. The additional challenge of on-site fabrication is that the work area must be kept clean and dry throughout the process. This is sometimes difficult on a construction site but is essential to ensuring that the integrity of the fibrous glass duct board be maintained prior to its installation.

2.7. Mold Growth Potential

2.7.1. Laboratory tests confirmed that fibrous glass ducts do not support mold growth.

According to NAIMA studies (1996), it has been incorrectly thought that microbes will use the resin bonding and the glass fibers in fibrous glass duct board as a food source to support mold growth. However, the glass fibers that make up the interior surface of fibrous glass duct board are inorganic and, therefore, do not support mold growth. Many fibrous glass duct boards are now produced with antimicrobial agents integrated into the surface to act as a preventative agent against the growth of mold on the airstream surface. In fact, the dust that accumulates in ductwork during normal system operation provides the food source to support mold growth. Fibrous glass duct board has passed the UL 181 Tests

Fibrous Glass Duct Board White Paper

for Long-Term Durability. Using the UL test procedure, duct samples containing mold mycelia and bread spores were placed in a dark chamber with high humidity for 60 days. The test result confirmed that fibrous glass duct insulations do not support microbial growth.

2.7.2. Research confirms that mold growth is not surface specific.

Mold growth studies conducted by researchers Thomann and Tulis at Duke University (1996) show that mold growth is not surface specific. Under similar conditions of temperature, water, and food (dust) availability, both fibrous glass duct board and galvanized metal ducts showed equal mold growth. Studies have shown that the presence of available water and food (dust) becomes the determining factor to mold growth, not the type of duct material. Researchers found that fungal growth was rarely observed on many different duct surfaces subjected to high-humidity air, even when exposed over extended periods of time. In contrast, fungal amplification was regularly observed where liquid water was introduced to the duct surfaces. Therefore, wherever liquid water was introduced to the system, microbial growth was observed on all surface types of ducts, including circular metal “flex” duct, the flat surfaces of metal ducts, plastic-lined flex duct, caulks and sealant, conditioning coils, metal sound attenuators, and internal duct liners.

Thomann and Tulis (1996) conclude that incidents of mold growth in ducts are not a duct material issue, but rather an operation and maintenance issue of the space conditioning system. Because eliminating all dust from the equation is impossible, it is imperative that the system is properly designed to eliminate water.

2.7.3. HVAC systems may create conditions that are suitable for mold growth on any duct material.

Operation of the HVAC systems may create conditions that are suitable for mold growth on any duct material. HVAC ducts fabricated from all types of materials will become contaminated with dust and dirt from normal system operation. Air carrying dust is continually returned through the system and filtration systems. Even when properly maintained, HVAC and filtration systems do not stop all of this dust transfer from occurring. This dust will continually travel through the HVAC unit and the ductwork, and will be deposited throughout the systems. This dust and dirt provides the food source for mold growth when combined with water. For this reason, it is essential that HVAC systems and ductwork are inspected yearly and cleaned as needed.

2.7.4. Standard uncoated fibrous glass duct board has a higher surface area than metal duct.

It is IBACOS' opinion that new generation duct boards reduce dust and moisture collection. Reduced roughness of coated and/or laminated duct board eliminates surface irregularities that provide higher surface areas for retention of moisture and dust.

For these reasons, it is most effective not to use fibrous glass duct board in certain instances. In particular, horizontal air-handling units, down-flow systems, and bottom return systems require careful attention. These situations are addressed in Section 3. Issues Specific to Fibrous Glass Duct Construction of this report.

Fibrous Glass Duct Board White Paper

2.8. Leakage

According to the International Code Council (2000), all joints and seams should be made airtight by means of an approved closure system. Closure systems used with rigid fibrous glass duct systems should comply with UL 181A.

Leakage of conditioned air out of supply ducts or non-conditioned air into return ducts can severely compromise the overall energy efficiency of an HVAC system. Fibrous glass duct systems, when installed according to manufacturer's recommendations, have minimal leakage. In a NAIMA test using a UL test procedure (1996), a flow meter measured leakage under positive pressure in an 8-foot fibrous glass duct section with both ends capped. A test was conducted on duct samples already exposed to static load, impact, pressure, or collapse tests. The result was that leakage in fibrous glass ducts does not exceed 20 times the static volume of the duct in a one-hour period, the maximum permitted by the UL standard.

2.9. Acoustic Performance

Noise in ductwork is created by the furnace blower, the blower turbulence, mechanical noise, and blower and motor vibration, as well as from the turbulence that is created from the movement of air through the ductwork. The attributes of fibrous glass duct board reduce these noises more than sheet metal (sheet metal can regenerate or amplify the noise, and transmits vibration to the house structure via hangers and other contact points) when common design techniques are used.

Based on NAIMA studies (2002), fibrous glass duct board reduces the noise associated with the blower, as well as the air turbulence within the duct. Also, fibrous glass duct board does not create duct noise by popping or booming due to expansion and contraction. It also helps to reduce room-to-room noise transfer.

2.10. System Application

Fibrous glass duct board may be used in a variety of residential purposes. It can be used in applications ranging from straight duct sections, elbows, and tees to offsets and other system elements. There are some specific areas within the duct system where fibrous glass duct board may not always be the recommended product because of the high potential for exposure to water. These applications will be discussed in detail in Section 3. Issues Specific to Fibrous Glass Duct Construction, of this report. Also, fibrous glass duct board should not be used in concrete, buried below grade, or any other location where it may be exposed to weather or physical abuse. In this section, some applications of fibrous glass duct board are presented.

Fibrous Glass Duct Board White Paper



Figure 2.

In Figure 2, the recommended use of fibrous glass duct board in an up-flow system on both the supply and return side of the furnace is illustrated. The fibrous glass duct board is used adjacent to the cooling coil on the supply side because this is an up-flow system. Note that this furnace has an adjacent return boot, which is appropriately fabricated out of fibrous glass duct board because it is not in direct line with the cooling coil.



Figure 3.

In the application shown in Figure 3, fibrous glass duct board should not be used in a down flow furnace, directly below the coil. This is one area where water may drop off of the coil into the ductwork. This is a clear example of an application where sheet metal should be used and provides a contrast to the suitable application of fibrous glass duct board shown in Figure 2.

Fibrous Glass Duct Board White Paper



Figure 4.

Figure 4 illustrates an advantage of fibrous glass duct board, when ductwork penetrates a ceiling plane into an attic. A key element of concern in this application is the air infiltration that can occur around the penetration through the ceiling plane at the ductwork. When using insulated flex, sealing around the duct becomes complicated because it is not rigid and because it is not a flat, consistent surface. Figure 4 depicts a side-by-side comparison of these two products where the supply is constructed of fibrous glass duct board but the return duct is insulated flex duct. Note the drywall support that has been added at the fibrous glass duct board penetration so that drywall can be applied flush with the product.



Figure 5.

In Figure 5, the advantages of using fibrous glass duct board for both the supply and return side are evident in the finished stage. By using fibrous glass duct board, the drywall can be cut closely around the duct. As well, because the fibrous glass duct board is rigid, the drywall can be taped and sealed with joint compound to the fibrous glass duct board. This creates an airtight seal that prevents air infiltration from the attic.

Fibrous Glass Duct Board White Paper



Figure 6.

In Figure 6, the application of fibrous glass duct board as a main trunk line in an attic is illustrated. Note the basic support system that is being used, demonstrating the rigidity of the fibrous glass duct board. When used in this application, ductwork can easily be insulated and installed in an attic, providing protection from the ambient attic air during all seasons.

Fibrous Glass Duct Board White Paper

2.11. Fire and Flame Resistance/Rating

The following information on fire and flame resistance is based on NAIMA testing (1996).

In a NAIMA test using UL 181 tests for fire safety, fibrous glass duct board met all applicable fire resistance standards.

A UL surface burning characteristics test was also conducted; this test is recognized as a standard test for evaluating all types of building materials as to their performance when exposed to heat and flame. The result is that fibrous glass duct systems are resistant to flame spread from external or internal fire sources, and are classified as Class 1 materials.

In flame penetration tests, the exterior surface of the fibrous glass duct material is subjected to a gas flame from a furnace. Fibrous glass ducts withstood the flame penetration test without collapse or evidence of perforation, which would allow direct passage of flame or gases, and without combustion on the exterior surface of the sample.

In a burning test, finished duct sections mounted in horizontal, vertical, and 45-degree positions are each exposed to a flame. The result is that fibrous glass ducts resist ignition by small, low-energy flames, like those from a burning wastebasket, and will not spread the fire.

2.12. Code Compliance

Fibrous glass duct board complies with UL 181 and is a Class 1 duct system. Refer to the *2000 International Mechanical Code* for current national mechanical code requirements. Most code requires using Class 0 or Class 1 duct materials that conform to the *SMACNA Fibrous Glass Duct Construction Standards* or *NAIMA Fibrous Glass Duct Construction Standards*.

2.13. Fiber Erosion

A concern is that fibers are eroded by the action of the air flowing over the fibrous glass duct board, delivering fibers to the occupied space. Fibrous glass duct board has been tested by NAIMA (1996) in high velocity test rigs that simulate the conditions of air movement, including impact of an air stream at a corner condition. The fibrous glass duct board is subjected to a four-hour test at 2½ times the manufacturers' maximum operating velocity. Also, NAIMA (1996) references a study by the Kettering Laboratory at the University of Cincinnati, which tested several fibrous duct systems with air velocities of 3,000 fpm for 136 continuous hours. Based on these test results, fibrous glass duct material does not deteriorate initially or show any other evidence of erosion or structural damage over the testing time period.

In addition to the testing, the physics of how ducts work further disprove the concern. After use, all ducts, whether metal or fibrous glass, build up a thin layer of dust. The dust is lighter than a glass fiber, and it lies on the surface of the duct, so it is highly unlikely that the fiber under the dust will be picked up and delivered somewhere else.

Fibrous Glass Duct Board White Paper

So when are fibers present? During fabrication, the fibrous glass duct board is cut with cutting tools to create joints. This cutting frees some fiber. After fabrication, the duct sections should be blown out, or vacuumed, reducing the amount of fiber available. After fabrication, fibers are not liberated, according to NAIMA (1996).

3. Issues Specific to Fibrous Glass Duct Construction

One of the concerns with fibrous glass duct board is its interior surface. Being composed of glass fibers that are rough when compared to smooth steel has caused many industry contractors to question whether fibrous glass duct board is a safe and durable option. Testing using UL test procedures, however, has proven that fibrous glass duct board is a safe and durable duct fabrication material. Discussed below are issues specific to fibrous glass duct construction, as well as testing results and industry research that address these concerns.

3.1. Air-handling units must be properly installed and maintained.

If air-handling systems are properly installed and maintained, the availability of water inside the ductwork is remote. Water does not collect in ductwork from condensation. Water does collect from poor drainage of condensate, and blow off from a coil. Under normal conditions, the velocity of air passing through the coil is low enough to not lift off water droplets from the wet surface of a cooling coil. As the air velocity across the coil increases, water drops may be ripped free and carried down the supply air stream to ductwork beyond. Several design and maintenance conditions could result in the following conditions:

1. *Improper sizing of the cooling coil.* When the cooling coil is undersized, when compared to the furnace, it reduces the free area and increases the velocity of the air as it goes through the coil. This condition creates the potential for blow-off.
2. *Restriction of airflow, allowing build-up of ice on the coil.* This can occur with an improperly sized cooling coil and/or restrictive ductwork in the plenum. These conditions restrict airflow across the cooling coil. When the cooling coil does not have adequate airflow across it, it becomes too cold, and ice build-up occurs.
3. *Restriction in free area of the coil due to dirt build-up on the coil surface.* This results from lack of proper maintenance on the system over time, allowing dirt to build up and reduce free area. This reduction of free area creates increased velocities and potential for ice build-up.
4. *Air bypassing the coil, picking up water from a poorly drained condensate pan.* When the coil is restricted, particularly in horizontal flow units, the air is delivered past the coil and picks water up from the pan. In severe conditions, the pan simply overflows.

These conditions are independent of duct material construction and result in similar wetting of both metal and fibrous glass ducts. The worst condition is in a down-flow unit, where gravity carries the condensate in the direction of the airflow. Any condensate that is carried over from the coil or leaks from the drain pan goes directly into the ductwork. In horizontal-flow units, the force of gravity is neutral relative to the airflow, but the force of the airflow is enough to push unwanted condensate into the ductwork. This water may show up as a leak, in addition to wetting the duct. While up-flow systems may still experience wetting due to improper design, they are not as susceptible as the other two configurations because gravity does not play a significant role.

Fibrous Glass Duct Board White Paper

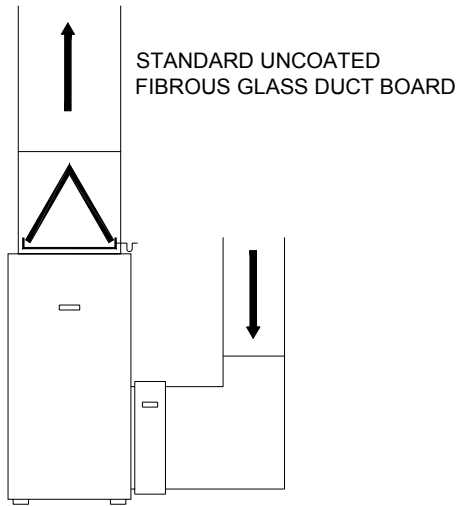

As shown in Figure 7, in an up-flow configuration, standard uncoated fibrous glass duct board may be used adjacent to the coil.

Figure 7.

In a horizontal supply system, there are two options that may be considered as shown in Figure 8. Metal duct, installed so that it slopes back to the furnace, may be used for the first four feet of duct adjacent to the coil. To prevent air infiltration, all seams and connections must be sealed with UL 181 approved closure system at ductwork joints. In addition, exterior insulation is to be used on the metal duct to prevent condensation potential. After four feet, the ductwork may be transitioned to standard uncoated fibrous glass duct board.

The other option is to use coated or laminated fibrous glass duct board adjacent to the coil for the first four feet. Again, this ductwork should be sloped back toward the furnace to prevent water from lying in the duct or running out through the duct system. All board edges must be sealed with a UL 181 approved closure system prior to fabrication to reduce the surface area of the exposed edge at seams. Standard uncoated fibrous glass duct board may be used after the first four feet of coated duct.

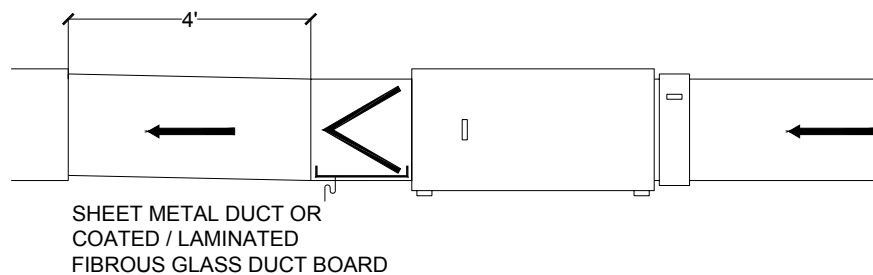

Figure 8.

Fibrous Glass Duct Board White Paper

For down-flow furnaces, sheet metal should be used directly below the coil and then for four feet in the ductwork adjacent to the coil. After four feet, the ductwork may be transitioned to standard uncoated fibrous glass duct board. This application is demonstrated in Figure 9.

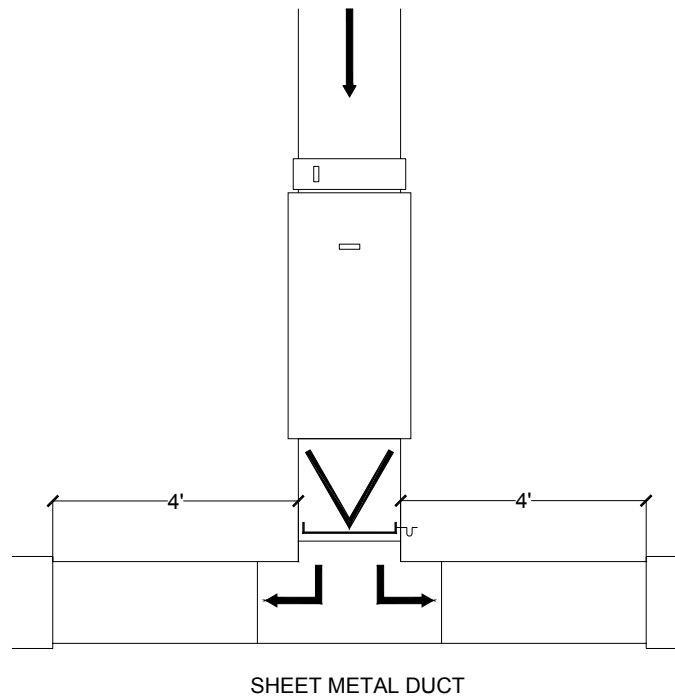

Figure 9.

3.2. Duct surfaces can become wet in the return plenum of up-flow systems.

The other location where duct surfaces can become wet is in the return plenum of up-flow systems. Many styles of air-handling units have supplied return air either through the sides of the fan section, or through the bottom of the unit, such as when the unit is set over a return box plenum. Wetting of these plenums directly below the air-handling unit occurs in several ways.

1. *After a cooling cycle, cool air drops off the coil above and chills surfaces.* In poorly sealed ductwork, humid exterior air can be introduced and cause some condensation. The solution is to use sealed ductwork on both supply and return, and to build in a vapor retarder and insulation to isolate the cool interior from a moist exterior. Fibrous glass duct board does this as an inherent aspect, while metal duct requires addition of well-executed insulation and vapor retarder application. The use of framing materials and gypsum wallboard should be avoided in up-flow return plenums, as they cannot be made airtight or insulated to control vapor access to cold surfaces.
2. *Inadequate maintenance or drainage of the condensate pan.* This can also result in flooding of the return plenum. Provision for coil maintenance and assurance of adequate drainage is required for elimination of these issues.

Fibrous Glass Duct Board White Paper

3. *Fall back of suspended water droplets.* Water droplets may be lifted off the coil for the same reasons as described for wetting of supply ducts downstream from air-handling units. In up-flow systems, the droplet will build up and wet the sides of the coil plenum and run down into the blower section of the system, eventually dropping into the plenum. This only happens with poorly designed or maintained systems. Construction of the return plenum from well sealed and insulated metal, or using faced or coated fibrous glass duct board, will allow a greater opportunity to identify and correct the air-handling unit issue before other damage occurs.

In an up-flow configuration with a side return, standard uncoated fibrous glass duct board may be used in the return adjacent to the furnace fan (Figure 10).

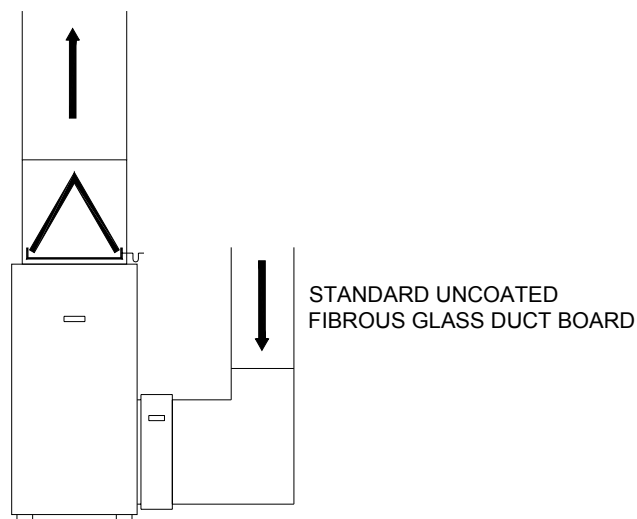

Figure 10.

For a horizontal supply system with a horizontal return, again, standard uncoated fibrous glass duct board may be used in the return adjacent to the furnace fan (Figure 11).

Fibrous Glass Duct Board White Paper

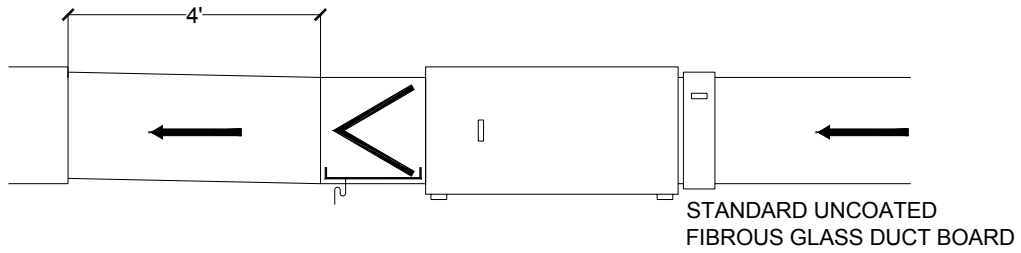

Figure 11.

For up-flow furnaces with a bottom return, sheet metal should be used in the return ductwork directly below the unit (Figure 12). In addition, the return boot should also be fabricated from sheet metal to prevent any water that may enter the system from collecting in the boot. From the return boot, standard uncoated fibrous glass duct board may be used for the rest of the return.

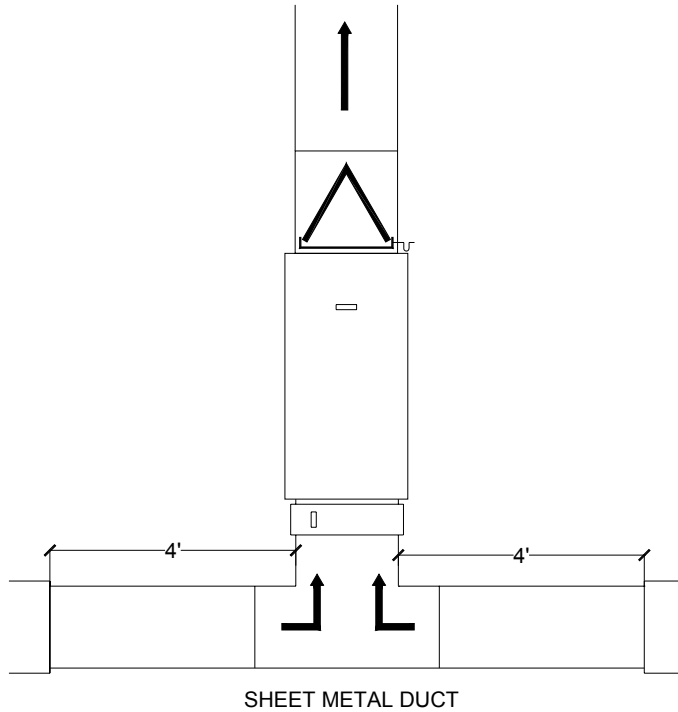

Figure 12.

4. Recommendations

IBACOS recommends:

- Following SMACNA's *Fibrous Glass Duct Construction Standards*, 6th edition (1992) or NAIMA's *Fibrous Glass Duct Construction Standards*, 2nd edition (1997) for constructing fibrous glass duct systems.
- In an up-flow configuration, standard uncoated fibrous glass duct board may be used adjacent to the coil plenum.
- In a horizontal supply system, there are two options that may be considered. Metal duct, installed so that it slopes back to the condensate pan, may be used for the first four feet of duct adjacent to the coil. To prevent air infiltration, all seams and connections must be sealed with a UL 181 approved closure system as outlined in NAIMA'S *Fibrous Glass Duct Construction Standards*, 2nd edition (1997). In addition, exterior insulation is to be used on the metal duct to prevent condensation potential. After four feet, the ductwork may be transitioned to standard uncoated fibrous glass duct board with all butt seams sealed with a UL 181 closure system. The other option is to use coated or laminated fibrous glass duct board adjacent to the coil. This ductwork should also be sloped back toward the furnace to prevent water from traveling through the duct system. Again, all board edges must be sealed with a UL 181 closure system prior to fabrication to reduce the surface area of the exposed edge. After four feet, the ductwork may be transitioned to standard uncoated fibrous glass duct board.
- For down-flow furnaces, sheet metal should be used directly below the unit and then for four feet in the ductwork adjacent to the coil plenum. Standard uncoated fibrous glass duct board may be used after the first four feet of coated duct.
- In an up-flow configuration with a side return, standard uncoated fibrous glass duct board may be used in the return adjacent to the furnace fan.
- In a horizontal supply system with a horizontal return, again, standard uncoated fibrous glass duct board may be used in the return adjacent to the furnace fan.
- For up-flow furnaces with a bottom return, sheet metal should be used in the return ductwork directly below the unit. In addition, the return boot should also be fabricated from sheet metal to prevent any water that may enter the system from collecting in the boot. From the return boot, standard uncoated fibrous glass duct board may be used for the rest of the return.

Fibrous Glass Duct Board White Paper

5. References

ASHRAE. ASHRAE Fundamentals Handbook. Atlanta, GA: ASHRAE. 2002.

International Code Council, Inc. International residential code for one- and two-family dwellings. Falls Church, VA: International Code Council. 2000.

NAIMA. Fibrous glass HVAC duct systems: proven performance. Pub. no. AH100. Alexandria, VA: NAIMA. September 1996.

NAIMA. A guide to insulated air duct systems. Pub. no. AH121. Alexandria, VA: NAIMA. January 1997.

NAIMA. Cleaning fibrous glass insulated air duct systems recommended practice. Pub. no. AH122. Alexandria, VA: NAIMA. March 1998.

NAIMA Fibrous glass duct construction standards. 5th ed. Alexandria, VA: NAIMA. 2002.

SMACNA. Fibrous glass duct construction standards. 6th ed. 1992.

International Code Council. International mechanical code 2000. Section 603, 603.4 Nonmetallic ducts. Falls Church, VA: International Code Council. 1999.

Thomann, Wayne R., and Jerry J. Tulis. Fungal contamination of HVAC surfaces: the role of the Dew point in microbial amplification." ASHRAE: Pathways to Better Building Environments conference. October 1996.